

# FLEXICODE

High-quality coding for individual packaging.



**DE KONINGH**  
CODING · LABELING · INSPECTION

Quality . Tradition . Innovation

## Flexicode – the solution for fast direct printing.

Flexicode is the ideal marking system when variable data is to be printed directly onto foil without first having to print a label. This direct print module is a budget-oriented entry-level system focused on important and basic functions.

Flexicode works with digital thermal transfer technology. This method stands for exceptionally good print quality and maximum reliability. Flexicode's easy maintenance, supported by a multitude of diagnostic functions, is an additional advantage.



### Ingenious casing design

---

The logical, well considered casing design offers a multitude of cable guiding options. Where space is extremely tight cable can be run up, down, behind and even to the side. All connections are arranged easily accessible and a clear wiring is ensured.



### Minimal operating costs

---

Flexicode delivers high quality marking on flexible packaging at low operating costs. Due to its great flexibility and the extraordinary length of the transfer ribbon, standstill times are reduced to a minimum when making production changes and replacing the transfer ribbon. The result is a lower consumption of materials - and thus lower costs.

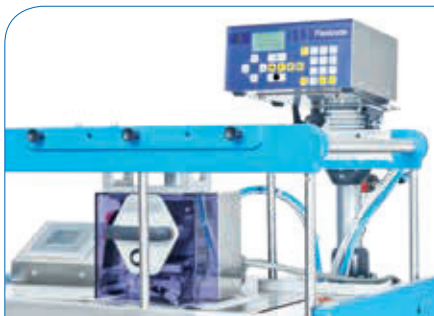

### First class adaptability

---

Flexicode provides all of the spatial prerequisites for integration in existing production and packaging systems: It is exceptionally small, lightweight and offers a multitude of attachment options. With variable bracket systems and support fittings, it can be adapted for every office - and this can be done fully flexibly and with a quick setup time.



### Unbeatable flexibility

---

Variable data such as date, time, batch number and bar codes are printed in high print quality directly onto the packaging foil or cardboard. Change of coding takes place either fully automatically or with the push of a button and therefore requires minimum setup times. Easy operation in conjunction with a high degree of reliability ensures maximum production times.



## Flexicode 53

<b>Printing</b>	
Print width	max 53 mm
Print length continuous mode intermittent mode	max 3000 mm max 40 mm
Print speed	50 ... 400 mm/s
Back speed	max 600 mm/s (intermittent mode only)
Bracket passage width	customized
Print resolution	300 dpi
Printhead	Corner Type
<b>Dimensions (width x height x depth)</b>	
Print mechanics w/o bracket system with bracket system	190 x 180 x 208 mm dependent on passage width
Control unit	242 x 117 x 220 mm
Connecting cable set to mechanics	2.5 m
<b>Weight</b>	
Print mechanics	6.0 kg
Electronics with cable	3.7 kg
<b>Acoustic Emission (distance 1 m)</b>	
Average sound power level	69 dB(A)
<b>Transfer Ribbons</b>	
Ink	outside or inside
Roll diameter	max 82 mm
Core diameter	25.4 mm / 1"
Length	max 450 m
<b>Interfaces</b>	
Serial	RS-232C (max 115,200 baud)
Parallel	Centronics (SPP)
USB	2.0 High Speed Slave
Ethernet	10/100 Base T, LPD, RawIP-Printing, DHCP, HTTP, FTP
2 x USB Master	connection for external USB keyboard and memory stick
<b>Connection Values</b>	
Pneumatic connection	6 bar dry and oil-free
Nominal voltage	230 V AC / 50 ... 60 Hz 1,5 A 115 V AC / 50 ... 60 Hz 3 A (option)
Fuse values	2x T4A 250 V
<b>Operating Conditions</b>	
Temperature	5 ... 40 °C
Relative humidity	max 80 % (non-condensing)
<b>Fonts</b>	
Font types	6 bitmap fonts   8 vector fonts/TrueType fonts   6 proportional fonts   more fonts on demand
Character sets	Windows 1250 to 1257, DOS 437, 850, 852, 857   all West and East European, Latin, Cyrillic, Greek and Arabic characters are supported   more character sets on demand
Bitmap fonts	size in width and height 0.8 – 5.6   zoom 2 – 9   orientation 0°, 90°, 180°, 270°
Vector fonts/TrueType fonts	6 BITSTREAM® fonts   size in width and height 1 – 99 mm variable zoom   orientation 360° in steps of 90°
Font attributes	dependent on font type – bold, italic, inverse, vertical
Character spacing	variable
<b>Bar Codes</b>	
1D bar codes	CODABAR, Code 128, Code 2/5 interleaved, Code 39, Code 39 extended, Code 93, EAN 13, EAN 8, EAN ADD ON, GS1-128, Identcode, ITF 14, Leitcode, Pharmacode, PZN 7 Code, PZN 8 Code, UPC-A, UPC-E
2D bar codes	Aztec Code, CODABLOCK F, DataMatrix, GS1 DataMatrix, MAXICODE, PDF 417, QR Code
GS1 bar codes	GS1 DataBar Expanded, GS1 DataBar Limited, GS1 DataBar Omnidirectional, GS1 DataBar Stacked, GS1 DataBar Stacked Omnidirectional, GS1 DataBar Truncated
all bar codes are variable in height, module width and ratio   orientation 0°, 90°, 180°, 270° check digit and human readable line optional	

Left version . Intermittent mode

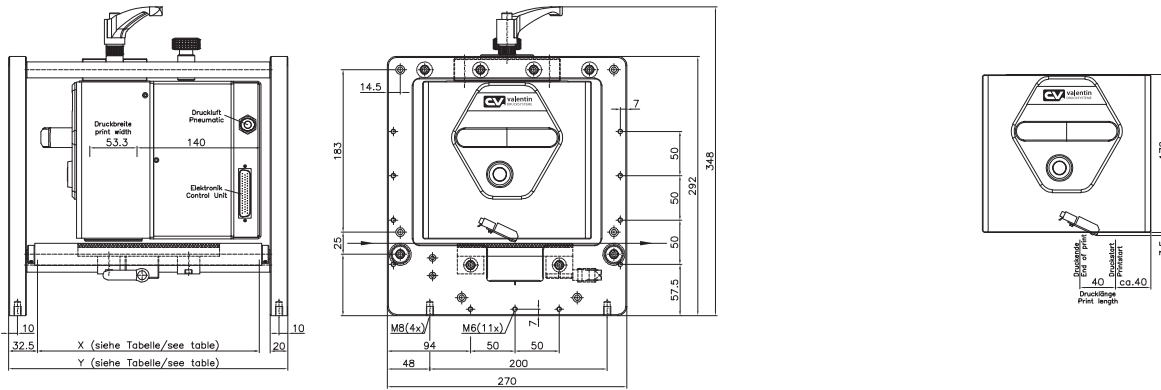

Durchlassbreite (X) Passage width (X)	250	340	430	470	620	770
Rahmenbreite (Y) Frame width (Y)	315	405	495	535	685	835

Left version . Continuous mode

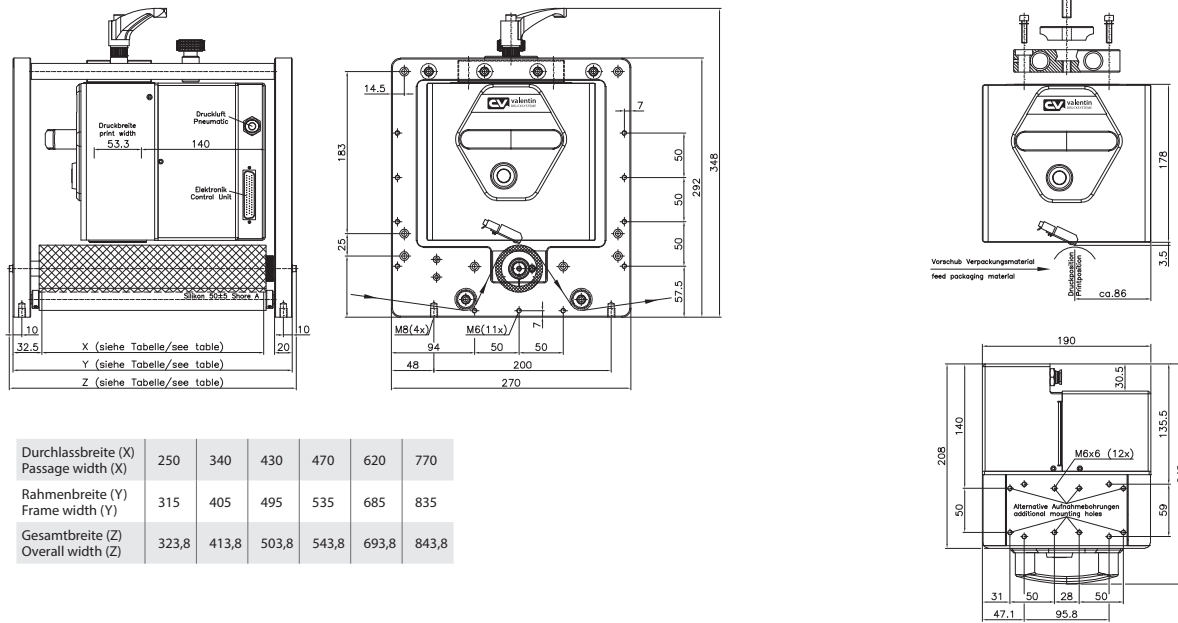

Durchlassbreite (X) Passage width (X)	250	340	430	470	620	770
Rahmenbreite (Y) Frame width (Y)	315	405	495	535	685	835
Gesamtbreite (Z) Overall width (Z)	323,8	413,8	503,8	543,8	693,8	843,8

Control unit

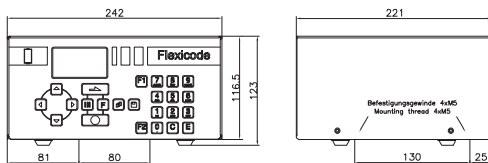

- Flexicode is as well available as right version (mirrored)
- all measurements in mm
- subject to technical changes



# FLEXICODE

compact . fast . direct

- > Intermittent mode and continuous mode selectable
- > Compact dimensions, multitude of attachment options
- > Problem-free network integration
- > Freely programmable printing system
- > Transfer ribbon prior warning
- > Quick access to real-time data
- > Synchronisation with packaging machines
- > Optimal user comfort and low maintenance
- > Low noise emission



Local retailer

# DE KONINGH

 **CODING · LABELING · INSPECTION**

Postbus 137, 6920 AC Duiven

Geograaf 8, 6921 E W Duiven

T: +31 (0)26 741 00 00

F: +31 (0)26 741 00 99

info@dekoningh.nl - www.dekoningh.nl